

RadiantWave™

OWNER'S MANUAL

Thermal Engineering Corporation

P.O. Box 868, Columbia, South Carolina 29202-0868

2741 The Boulevard, Columbia, South Carolina 29209

Telephone: (803) 783-0750 Toll-free (800) 331-0097

Fax : (803) 783-0756 Toll-free fax: (888) 581-0286

Website: www.tecinfrared.com

Warnings

FOR YOUR SAFETY

IF YOU SMELL GAS:

1. **SHUT OFF GAS TO THE APPLIANCE.**
2. **EXTINGUISH ANY OPEN FLAME.**
3. **OPEN LID.**
4. **IF ODOR CONTINUES, IMMEDIATELY CALL YOUR GAS SUPPLIER OR YOUR FIRE DEPARTMENT.**

FOR YOUR SAFETY

1. **DO NOT STORE OR USE GASOLINE OR OTHER FLAMMABLE VAPORS OR LIQUIDS IN THE VICINITY OF THIS OR ANY OTHER APPLIANCE.**
2. **AN LP CYLINDER NOT CONNECTED FOR USE SHALL NOT BE STORED IN THE VICINITY OF THIS OR ANY OTHER APPLIANCE.**

Warnings to Customer

DO NOT INSTALL OR OPERATE THIS APPLIANCE WITHOUT HAVING CAREFULLY READ THIS MANUAL. FOR FUTURE REFERENCE, HAVE THIS MANUAL AVAILABLE WHILE USING THIS APPLIANCE AND ALWAYS FOLLOW THE INSTRUCTIONS PROVIDED.

NEVER ATTEMPT TO MAKE CONVERSIONS OR MODIFICATIONS TO YOUR GRILL WITHOUT FIRST OBTAINING WRITTEN INSTRUCTIONS FROM THERMAL ENGINEERING CORPORATION.

DO NOT STORE A SPARE GAS CYLINDER UNDER OR WITHIN 15 FEET OF THIS GRILL, ANY OTHER OPEN FLAME, HEAT PRODUCING APPLIANCE OR HEAT SOURCE. FAILURE TO FOLLOW THESE INSTRUCTIONS CAN RESULT IN A FIRE CAUSING DEATH OR SERIOUS INJURY OR PROPERTY DAMAGE.

DO NOT ALLOW YOUR LP GAS CYLINDER TO BE FILLED BEYOND $\frac{3}{4}$ FULL.

Notices

Notice to Customer

PRIOR TO INSTALLING AND USING THIS APPLIANCE, READ THIS MANUAL FULLY AND CAREFULLY. RETAIN THIS MANUAL FOR FUTURE REFERENCE AND HAVE AVAILABLE AT ALL TIMES. ENSURE THAT ALL PERSONS OPERATING THIS EQUIPMENT CAREFULLY READ AND BECOME FAMILIAR WITH THE INFORMATION IN THIS MANUAL.

THIS UNIT HAS BEEN CAREFULLY INSPECTED AND PACKAGED AT THE FACTORY PRIOR TO SHIPMENT. UPON ARRIVAL, INSPECT THE APPLIANCE CAREFULLY FOR ANY CONCEALED DAMAGE. IMMEDIATELY REPORT ANY DAMAGE TO YOUR AUTHORIZED DEALER.

SHOULD YOU HAVE ANY QUESTIONS REGARDING OPERATION OR USE OF THIS APPLIANCE, CONTACT THERMAL ENGINEERING CORPORATION AT (803) 783-0750 OR 1-800-331-0097.

Notice to Installer

INSTALLATION MUST CONFORM TO LOCAL CODES OR THE NATIONAL FUEL GAS CODE, ANSI Z223.1/NFPA 54. IN CANADA, INSTALLATION OF THIS PRODUCT SHOULD BE IN ACCORDANCE WITH THE CAN/CGA-B149.1 NATURAL GAS AND PROPANE INSTALLATION CODE. FOLLOWING INSTALLATION, LEAVE THIS OPERATIONS MANUAL WITH THE CONSUMER FOR FUTURE REFERENCE. THIS APPLIANCE IS NOT INTENDED FOR USE ON RECREATIONAL VEHICLES AND/OR BOATS.



NATIONALLY REGISTERED TESTING LABORATORY

U.S. Patent # 6114666
U.S. Patent # 4886044
U.S. Patent # 4321857
Des. 266,050

© Thermal Engineering Corporation, Revised (9/04)

Limited Warranty

EXPRESS WARRANTIES

Thermal Engineering Corporation (TEC) warrants this grill to be free of defects in material and workmanship when subjected to normal domestic use and service from the date of purchase.

ONE YEAR LABOR

One year labor warranty covers all components and parts.

LIFETIME

All outer stainless steel structural components and parts are warranted for the life of the product to the original owner. All other components are warranted for five (5) years.

UNDER THIS WARRANTY

We will, at our option, repair or replace any component part deemed by TEC to be defective when returned to a TEC authorized dealer or to our factory, freight prepaid, within the warranty period. Prior to authorization of repair or replacement, you must supply the date of original purchase and serial number of your grill.

This warranty excludes damage caused by failure to follow the instructions in your Owner's Manual or alteration of the grill structure or components, or from operator abuse, negligence or accident.

DISCLAIMER OF IMPLIED WARRANTIES

This warranty excludes incidental and consequential damages. Except as stated above, all other warranties, including *implied warranties of merchantability and fitness for a particular purpose*, are excluded.

If you have questions concerning this warranty, please call your local authorized TEC dealer or call us at (803) 783-0750 or 1-800-331-0097.

Thermal Engineering Corporation

P.O. Box 868, Columbia, South Carolina 29202-0868
2741 The Boulevard, Columbia, South Carolina 29209
Telephone: (803) 783-0750 Toll-free (800) 331-0097
Facsimile: (803) 783-0756 Toll-free (888) 581-0286
Website: www.tecinfrared.com

MODEL #: _____

SERIAL #: _____

(See rating plate found on the rear of the grill.)

DEALER NAME: _____

DEALER TELEPHONE: _____

(Complete the above information for future reference.)

Dear TEC Infra-Red Grill Owner:

Thank you for selecting a TEC Infra-Red grill. You're among a select group who truly appreciate fine cooking and demand the best and we at TEC appreciate your confidence in our products.

I know you'll be pleased with your grill performance. Over the years, we've invested great resources in developing grills that are truly unique in terms of their sturdy, long-lasting construction, their cooking versatility and TEC's innovative infra-red cooking processes.

We've developed this manual to give you an overview of your grill and to help you get the most from it. We've included some cooking guidelines for you to use until you develop your own techniques. We've also included vital information about how to set up, operate and maintain your grill safely and correctly, so I urge you to read it carefully before first using your grill. If, after reviewing this information, you have any questions whatsoever, please call your Authorized TEC Dealer or our Customer Service Department at 1-800-331-0097 for help.

As I'm sure you know, we also offer a complete line of accessories that afford you a wide range of opportunities for new and interesting uses of your grill. Some of them, like our rotisserie, are options familiar to everyone. Others, like our deep fryer and wok, are truly unique enhancements that allow you to be adventuresome and inventive with your grill. Appendix A to this owner's manual explains the uses of these accessories. Your dealer also can tell you more about all the accessories we offer and their many uses.

If you have comments, suggestions, or even compliments, please pass them along to us. We are continually in search of ways we can improve our customers' experiences with their grills, starting when they first remove them from the box and continuing as they use them over the years. Hearing what you feel we could improve, as well as what you especially like about our products and services, is essential to this effort. To facilitate this feedback, a Product Registration Form is included with your grill. We would be grateful if you would take a few minutes to complete it and send it to us -- after you've used your new TEC a few times. We'll send you a free TEC apron as a token of our appreciation!

Happy grilling!

Best regards,

David O'Kelly
President

THERMAL ENGINEERING CORPORATION
Consumer and Commercial Products Division

Contents

- Installation.....4**
 - General Overview
- Assembly.....5**
 - General Overview
 - Radiant Glass Emitter
 - Cooking Grids and Warming Rack
 - Side Shelf
 - Trim Kit
- Gas Connection6**
 - General Overview
 - LP Gas Cylinder Safety
 - Installing Your LP Gas Cylinder
 - Removing Your LP Gas Cylinder
 - Permanent Installation
 - Gas Leak Test
- Operation9**
 - General Overview
 - Burner Ignition and Operation
 - Burner Ignition With Match
 - Low Heat Adjustment
 - Hazardous Locations and Conditions
- Infra-red Cooking12**
 - General Overview
 - Infra-red Searing Method
 - Smoking Method
 - Helpful Hints in Cooking
 - Flame Flare-up Control
 - Sample Cooking Methods
- Maintenance and Cleaning14**
 - General Overview
 - Care of Radiant Glass Emitter
 - Protection of Burners
 - Cleaning
 - Maintenance
 - Replacement Parts
- Appendix A: Accessories16**
 - Rotisserie
 - Deep Fryer/Steamer
 - Steamer
 - Griddle
 - Wok
- Appendix B: Replacement Parts.....21**
- Appendix C: Troubleshooting22**

Installation

General Overview

WARNING: THIS GRILL IS DESIGN CERTIFIED FOR USE OUTDOORS ONLY. THIS GRILL SHOULD NOT BE USED IN A BUILDING, GARAGE OR OTHER ENCLOSED AREA AND IS NOT INTENDED FOR USE ON RECREATIONAL VEHICLES OR BOATS.

WARNING: THIS OUTDOOR COOKING GAS APPLIANCE SHALL NOT BE USED UNDER OVERHEAD COMBUSTIBLE CONSTRUCTION.

The RadiantWave is designed for use on the pedestal base attached to the unit when shipped. The RadiantWave is not designed for build-in/enclosure applications. The RadiantWave must only be used with its integral pedestal base. Figure 1 (see page 5) represents the minimum clearance of a mobile grill to any adjacent combustible construction.

The installation of your grill must conform to local codes or, in absence of local codes, the National Fuel Gas Code ANSI Z223.1/NFPA 54. In Canada, the installation must conform to local codes and/or the Natural Gas and Propane Installation Code CAN/CGA-B149.1.

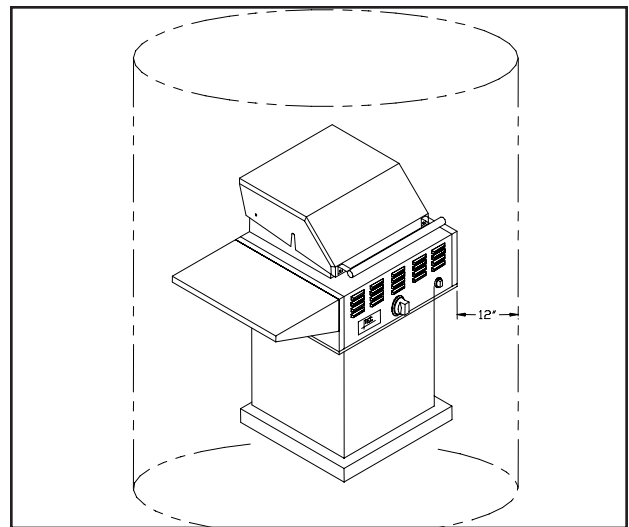

Figure 1. Clearance to Combustible Construction

	COMBUSTIBLE CONSTRUCTION
Sides	12"
Back	12"

Table A.1 Clearance Specifications

Assembly

General Overview

Except for attachment of the side-shelf, the RadiantWave is shipped from the factory completely assembled. You will need to unpack the unit and place the Radiant Glass Emitter, the Cooking Grids and the Warming Rack in their proper locations. Assembly procedures for each of these items follow.

Radiant Glass Emitter

1. Remove the Radiant Glass Emitter from the packaging material.
2. Place the Radiant Glass Emitter with the smooth side up on the brackets directly above the burner assembly.

Cooking Grid and Warming Rack

1. Remove the Cooking Grid and Warming Rack from the packaging materials.
2. Set the Cooking Grids in place with the closed side of the channels facing up. Set the Warming Rack in place on top of the ledge of the fixed portion of the Hood.

Side Shelf

Tools Required

- Phillips screwdriver (#2)

1. Remove white protective plastic from Side Shelf.
2. Locate the three top side panel screws.
3. Locate the two upper front and back side panel screws. Remove the two top ones and loosen the two bottom ones.

Helpful Hint: Loosen the bottom screws so that the the bottom holes slots will hold up the side shelf. This will make it easier to adjust top screws.

4. Place the shelf on the bottom screws.
5. While holding the shelf up, screw in the top corner screws and tighten.
6. Screw in the remaining screws and tighten the bottom screws.

Note: TEC grill covers for one side shelf are made only for the shelf to be mounted on the left side of the grill.

Trim Kit

1. Remove white protective plastic from the four (4) trim pieces:
 - Two (2) 16 5/8" x 1"
 - Two (2) 17 7/8" x 1 1/2"
2. Insert 1" trim, flat side up, in front of the cooking grid.
3. Insert the other 1" trim, flat side up, behind the cooking grid.
4. Insert 1 1/2" trims, flat side up, on left and right side of the cooking grid.

Gas Connection

General Overview

WARNING: THE GAS SUPPLY HOSE SHOULD BE INSPECTED PRIOR TO EACH USE. DO NOT USE A GAS HOSE THAT HAS ABRASION, CUTS OR EXCESSIVE WEAR. IF DAMAGE IS PRESENT THE HOSE MUST BE REPLACED WITH A TEC SPECIFIED HOSE PRIOR TO USING THE GRILL. A LIST OF REPLACEMENT PARTS CAN BE FOUND IN APPENDIX B.

WARNING: WHEN YOUR GRILL IS STORED INDOORS, REMOVE AND STORE THE LP GAS CYLINDER OUTDOORS IN A PROTECTED, COOL AND DRY LOCATION OUT OF REACH OF CHILDREN. THE CYLINDER SHOULD NOT BE STORED IN A BUILDING, GARAGE OR ANY OTHER ENCLOSED AREA.

Follow the procedures outlined in this section closely to ensure safe and proper grill operation. The RadiantWave grill is offered in one of two gas configurations: LP or Natural gas. Reference Table A.1 below for regulator specifications. Grills that do not use LP gas with standard 20 lb. LP cylinder must be installed by qualified personnel. This includes all Natural gas and permanently installed LP units. Gas regulators specified by TEC must be used at all times.

Refer to Table A.1 below for gas supply specifications or see rating plate located on the rear of the grill.

LP Gas Cylinder Safety

WARNING: WHEN PURCHASED FOR USE WITH LP GAS, THE RADIANTWAVE GRILL COMES WITH A REGULATOR ASSEMBLY THAT USES A TYPE I CYLINDER CONNECTION DEVICE. THIS DEVICE MUST BE USED WITH A TYPE I VALVE CYLINDER CONNECTION.

NOTICE: AN LP GAS CYLINDER IS NOT PROVIDED FROM THE FACTORY WITH THIS GRILL. HOWEVER, ONLY APPROVED 20 LB. LP GAS CYLINDERS CONSTRUCTED AND MARKED IN ACCORDANCE WITH THE SPECIFICATIONS FOR LP GAS CYLINDERS OF THE U.S. DEPARTMENT OF TRANSPORTATION (D.O.T) OR NATIONAL STANDARD OF CANADA, CAN/CGA-B339, CYLINDERS, SPHERES AND TUBES FOR THE TRANSPORTATION OF DANGEROUS GOODS; AND COMMISSION, SHOULD BE USED. ALL APPROVED CYLINDERS MUST BE EQUIPPED WITH AN INTEGRAL COLLAR DESIGNED TO PROTECT THE CYLINDER VALVE FROM DAMAGE, AS WELL AS A LISTED OVERFILL PROTECTION DEVICE. DO NOT USE OR TRY TO REPAIR A DAMAGED LP GAS CYLINDER AT ANY TIME. CONTACT YOUR LOCAL LP GAS SUPPLIER FOR REPLACEMENT. ALSO, YOU SHOULD ALWAYS OBSERVE THE FOLLOWING PRECAUTIONS:

- Store spare or extra gas cylinders at least 15 feet from this grill or other open flame, heat-producing appliance or heat source.
- Do not fill your gas cylinder beyond $\frac{3}{4}$ full.
- Gas cylinders come with a pressure relief valve. If a cylinder is subjected to excess heat, the relief valve will open and let highly flammable gas vapor and/or liquid escape. Therefore, do not store gas cylinders near an open flame or source of heat. Store cylinders only in well ventilated areas.

WARNING: FAILURE TO FOLLOW THE ABOVE PRECAUTIONS COULD RESULT IN A FIRE CAUSING DEATH OR SERIOUS INJURY OR PROPERTY DAMAGE.

GAS, REGULATOR AND BASE TYPE	SUPPLY PRESSURE (IN. WC (kPa), MAX/MIN)	OPERATING PRESSURE (IN. WC (kPa))	MAIN BURNER ORIFICE SIZE (DMS / DIA.)	BURNER OUTPUT (BTU/HR. (W)/EA.)
Natural model RV-47L (NG) stationary	7.0 (1.7)/5.0 (1.2)	4.0 (1.0)	40 (0.0980")	28,000 (8,210)
LP model RV-47L (LP) stationary	14.0 (3.4)/12.0 (3.0)	11.0 (2.7)	53 (0.0595")	28,000 (8,210)
LP model 5001 or 718A w/ hose 20 lb. cylinder	125 psi (861), max	11.0 (2.7)	53 (0.0595")	28,000 (8,210)

Table A.1. Gas Supply Specifications

Gas Connection continued

Installing Your LP Gas Cylinder

NOTICE: FOR YOUR SAFETY, ONLY USE THE REGULATOR AND HOSE ASSEMBLY PROVIDED AS ORIGINAL EQUIPMENT WITH YOUR GRILL.

NOTICE: A FIRE EXTINGUISHER FOR CLASS A, B, C & D FIRES SHOULD BE READILY AVAILABLE AT ALL TIMES.

WARNING: THE VENTILATION/ACCESS OPENING FOR THE TANK, IN THE REAR OF THE PEDESTAL, MUST BE FREE AND CLEAR FROM DEBRIS. THE GAS MUST BE TURNED OFF AT THE SUPPLY SOURCE WHEN THE GRILL IS NOT IN USE.

Be sure to set the gas cylinder upright so the Cylinder Valve is at the top. This will ensure proper vapor withdrawal.

When you connect your cylinder to the grill, you will feel the coupling nipple seal when there is slight resistance. (See Figure 2.) Turn about one-half to three-quarters further to complete the connection. Tighten only by hand; do not use tools. If you cannot complete the final connection, disconnect the regulator and repeat step 7, below. If you are still unable to complete the connection, replace the valve and regulator!

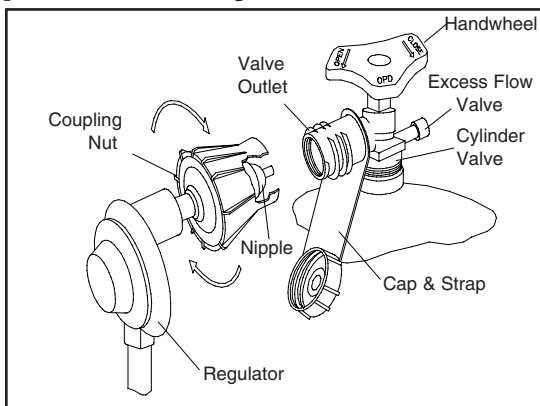

Figure 2. Coupling Assembly

Procedure:

1. In order to make sure the Cylinder Valve is fully closed, turn the Handwheel clockwise until it stops.
2. Turn all burner controls OFF.
3. Move your grill to an open area that's level.
4. Place the gas cylinder in the space provided in the pedestal and secure the tank with the tank strap latch assembly (See Figure 3). Remove the protective caps from Cylinder Valve Outlet and Nipple, as necessary.
5. Inspect the Coupling Nut, Nipple and Cylinder Valve for any damage, dirt or debris. Remove dirt or debris. Replace any damaged parts with TEC specified replacement parts prior to use.
6. Inspect Regulator and Hose Assembly for any damage, dirt or debris. Remove dirt or debris. Replace any damaged parts prior to use.
7. With the Regulator in your hand, insert the Nipple into the Cylinder Valve. Make sure the Nipple is centered in the Cylinder Valve outlet. Tighten the Coupling Nut by hand, making sure not to cross-thread the connection.

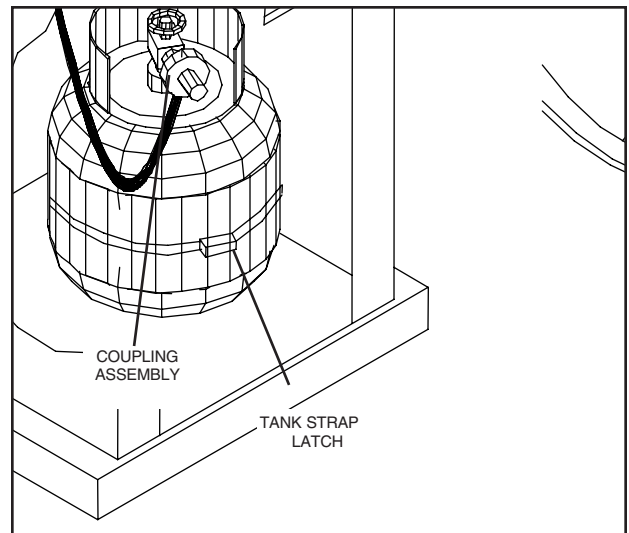

Figure 3. Gas Tank Placement

Gas Connection continued

Removing Your LP Gas Cylinder

Procedure:

1. Close the Cylinder Valve by turning the Handwheel clockwise until it stops.
2. Remove the Coupling Nut from the Tank Valve Outlet by turning it counter-clockwise.
3. Release the latch and remove the cylinder from grill.

Permanent Installation

CAUTION: GAS PIPING TO YOUR GRILL MUST BE IN ACCORDANCE WITH LOCAL CODES. IN THE ABSENCE OF LOCAL CODES, USE THE NATIONAL FUEL GAS CODE ANSI Z223.1/NFPA 54 (LATEST EDITION) OR CAN/CGA B-149.1, NATURAL GAS AND PROPANE INSTALLATION CODE.

CAUTION: THE GAS SUPPLY MUST BE TURNED OFF AT THE GRILL WHEN THIS APPLIANCE IS NOT IN USE.

When ordered for use with Natural gas, the RadiantWave grill comes adjusted to operate with Natural gas.

Qualified personnel should install the gas line. A Shut-off Valve at the grill is required. This Valve must be design certified by CSA International.

The grill and Shut-off Valve must be disconnected from the gas supply piping system during any pressure testing of the system at test pressures in excess of $\frac{1}{2}$ PSIG (3.5 kPa).

The grill must be isolated from the gas supply piping system by closing its individual manual Shut-off Valve during any pressure testing of the system at test pressures equal to or less than $\frac{1}{2}$ PSIG (3.5 kPa).

Gas Leak Test

WARNING: DO NOT USE OPEN FLAME TO PERFORM LEAK TEST!

WARNING: DO NOT ATTEMPT TO USE THE GRILL WHEN YOU SMELL GAS OR FAIL A GAS LEAK TEST.

Make sure there is no open flame near the grill during the test. Test for leaks every time the gas is re-connected.

Procedure:

1. Turn all controls to OFF.
2. Open the Gas Supply Valve slowly. Apply soapy water solution to all connections including factory connections.
3. Look for bubbles around the connections. If bubbles can be seen, close the Valve and tighten the connection where the bubbles are. Then, repeat steps 1 and 2. Make sure you don't over-tighten the connections.
4. Proceed with grill use.

Operation

General Overview

NOTICE: THE BURNER VENTURI TUBES SHOULD BE INSPECTED FOR SPIDER WEBS AND OTHER OBSTRUCTIONS PRIOR TO EACH USE. IF ANYTHING IS FOUND, CLEAN THE TUBES COMPLETELY. A CLOGGED TUBE CAN LEAD TO A FIRE BENEATH THE GRILL.

NOTICE: NEVER OPERATE THE RADIANTWAVE WITHOUT THE RADIANT GLASS EMITTER PROPERLY INSTALLED AS DESCRIBED ON PAGE 5. THE BURNER SHOULD NOT COME IN CONTACT WITH WATER OR OTHER CLEANING FLUIDS, WHICH CAN DAMAGE THE BURNER, CAUSING IT TO FUNCTION IMPROPERLY.

Burner Ignition and Operation

Procedure:

1. If ignition does not occur in 5 seconds, turn burner to OFF, wait 5 minutes, and repeat lighting procedure.
2. Open the grill hood. Ensure the Gas Valve is closed and that the top of the cooking grid is not covered.
3. For LP gas, open the Gas Valve on the Cylinder using the Handwheel.(See Figure 2, Page 7.) For Natural gas, open the gas valve in the main line.
4. Depress and rotate the Burner Output Knob to HIGH. (See Figure 5.)
5. Slowly rotate Spark Igniter knob clockwise twice and check for flame. If flame is not present turn Burner Output Knob to OFF and wait 5 minutes. Repeat steps 4 and 5.
6. For maximum cooking speed and searing intensity, maintain the Burner Output Knob at HIGH for 1 to 2 minutes with the hood open, then close the hood and continue operation at HIGH for an additional 7 to 9 minutes to accomplish a total preheat time of 8 to 10 minutes on HIGH. For slow cooking, maintain Burner Output Knob at HIGH for 3 to 5 minutes with the hood open. Then, rotate Burner Output Knob to desired cooking level.
7. To extinguish the flame, depress and rotate the Burner Output Knobs to OFF.

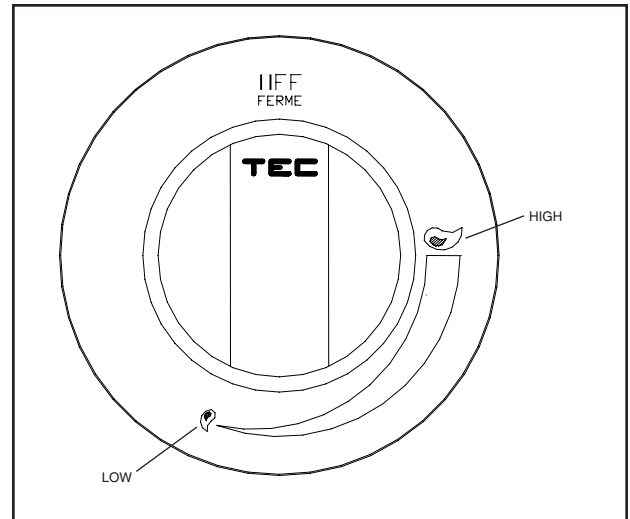

Figure 5. Burner Output Knob

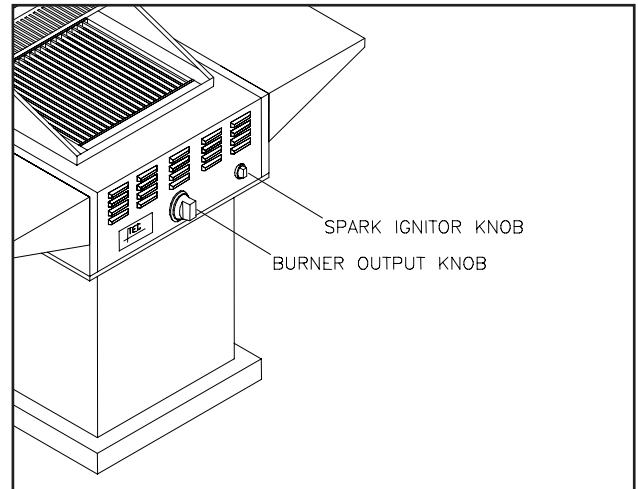

Figure 6. Grill Knobs

Operation continued

Burner Ignition With Match

If your spark ignition system is not working properly, the burner may be ignited manually, using a match. Use the following procedure to do so.

CAUTION: DO NOT HOLD A MATCH IN YOUR HAND ABOVE THE BURNER WHEN LIGHTING THE BURNER MANUALLY. PLACE A LIT MATCH IN THE MATCH HOLDER, THEN INSERT THE LIT MATCH THROUGH THE SPACE BETWEEN THE RADIANT GLASS EMITTER AND THE LEFT SIDE OF HEAT SHIELD TO LIGHT THE BURNER AS DESCRIBED BELOW.

Procedure:

1. If ignition does not occur in 5 seconds, turn the Burner control knob to OFF, wait 5 minutes, and repeat the lighting procedure.
2. Ensure the gas valve is closed and that the cooking grid is not covered.
3. For LP gas, open the Gas Valve on the Cylinder using the Handwheel. (See Figure 2, Page 7.)
For Natural gas, open the gas valve in the main line.
4. Pull the match holder out of its storage hole in the left underside of the cooking unit and fully extend the cable to which it is attached.
5. Place a lit match in the match holder, then place the lit match between the Radiant Glass Emitter and the left side of the heat shield, angling it inward so that the match flame is directly over the burner.
6. While watching the flame to ensure that the match remains lit, turn the Burner Output Knob to HIGH to ignite the burner. If the match flame goes out before the burner lights, turn the Burner Output Knob to OFF immediately, wait two minutes and repeat this step. Never turn the Burner Output Knob from the OFF position if you do not see a flame from the match appropriately positioned above the burner surface.
7. Operate and adjust the burner as described in Step 6 of the Burner Ignition and Operation Procedures on Page 9.
8. To extinguish the flame, depress and turn the Burner Output Knob to OFF.

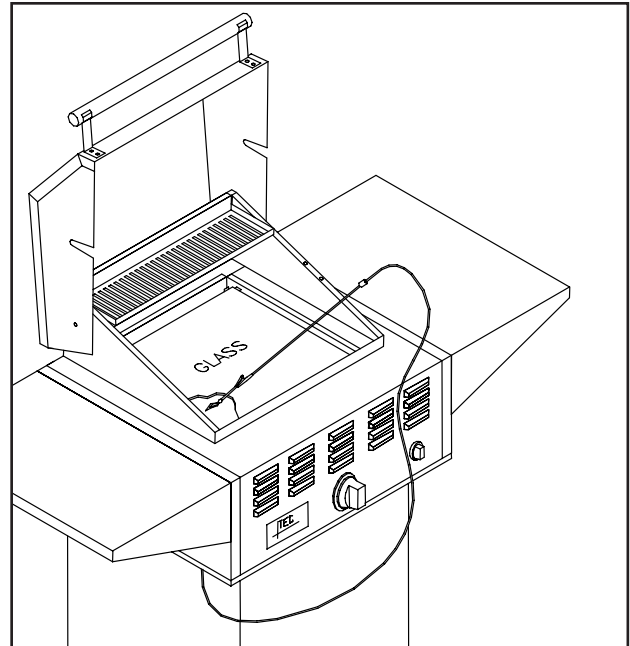

Figure 7. Match Lighting

Burner Flame

The burner flame should be approximately 1/2" tall when the burner is in operation (See Figure 8).

WARNING: THE GAS ORIFICE MUST BE PROPERLY LOCATED ON THE ORIFICE BRACKET, WHICH IS ATTACHED TO THE VENTURI ON THE BURNER ASSEMBLY. AN IMPROPERLY LOCATED ORIFICE CAN LEAD TO BODILY INJURY AND PROPERTY DAMAGE. THE PROPER LOCATION IS SHOWN IN FIGURE 8.

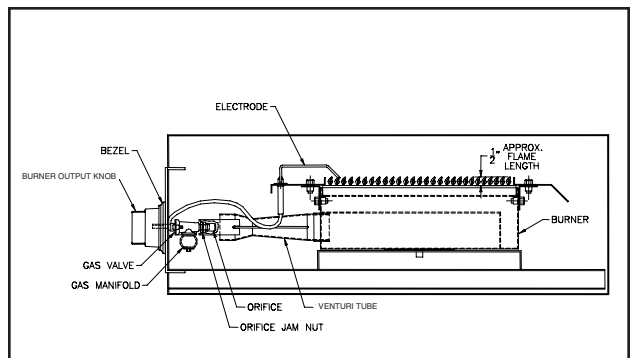

Figure 8. Burner Flame and Orifice Location

Operation continued

Low Heat Adjustment

The burner's LOW heat output is preset at the factory. If you need to adjust this setting due to a particular cooking style, follow the instructions below.

WARNING: NEVER ADJUST THE BURNER SO LOW THAT IT MAY GO OUT DURING USE. DO NOT OPERATE GRILL WITH DISENGAGED LOW HEAT ADJUSTMENT SCREW.

The Low Heat Adjustment Screw only applies to the burner operation at the LOW setting. Any efforts to make adjustments at another setting will go unnoticed until the burner is turned to LOW, where it may involuntarily extinguish while gas is still flowing. This condition is unsafe and therefore adjustments should only be made with the Burner Output Knob positioned at the LOW setting while keeping a close eye on changes.

Please note that this procedure is best performed at night to maximize visibility of the burner flame.

Procedure:

1. Remove the Cooking Grid to improve the visibility of the burner. Follow the Burner Ignition procedures and operate the grill for 5 minutes or until the ceramic burner glows bright yellow-orange consistently over the entire surface.
2. Turn the Burner Output Knob to the LOW position and wait until the temperature drops and stabilizes.
3. Remove the Burner Output Knob from the valve stem. (See Figure 9.)
4. Insert a small blade screwdriver into the Valve Stem.
5. Turn the Low Heat Adjustment Screw clockwise to reduce the heat intensity or counter-clockwise to increase the heat intensity. At its optimal low heat adjustment, the burner input will be just high enough to produce a consistent, low-intensity glow without fluttering. To accomplish this, view the burner by looking down under the right or left side of the glass while turning the adjustment screw.

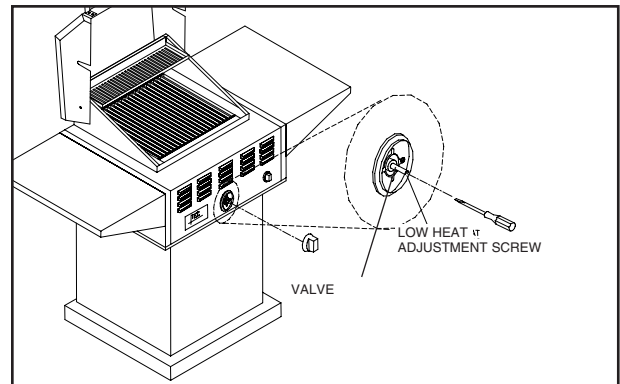

Figure 9. Low Heat Adjustment

Hazardous Locations and Conditions

- When cooking, keep your grill at least twelve inches from combustible surfaces (wood, wall or wooden fence, etc.). DO NOT locate the grill under any combustible material (i.e. wood, canvas, thatch, plastic, etc.).
- Do not block the flow of combustion and ventilation air.
- Only use your grill outside in a well-ventilated area. Do not cook in a building, garage, or any other enclosed area.
- Keep flammable substances away from the grill, including aerosols and aerosol containers, gasoline and similar liquids, paper and paper products, containers of grease, paint, etc.
- Never leave your grill unattended while it is in operation.
- Do not wear flammable and/or loose clothing, such as long sleeves, neckties, scarves, etc., while using the grill.

Infra-red Cooking

General Overview

Now that you are ready to begin cooking, you can enjoy cooking outdoors quickly and effortlessly. You can enjoy steaks, hamburgers, poultry, pork chops, roasts, fish and other foods in just minutes if you wish. But you can also cook more slowly. TEC's optional accessories are designed to enhance your grill versatility.

Infra-red Searing Method

Searing is a process that seals juices in food by cooking with intense heat for a short period of time. The juices stay in the food where they belong while the outside takes on a grilled flavor. For best results, follow these procedures when cooking.

The intense infra-red energy generated by your TEC grill has many advantages. For example, food is evenly cooked throughout. Also, grease and food particles burn up on contact with the Radiant Glass Emitter and change into flavorful vapors that cook back into the food. Follow the procedures below:

1. Follow the Burner Ignition Procedures at pages 9 and 10. In particular, follow the instructions for "maximum cooking speed and searing intensity" in Step 6 on page 9 under Burner Ignition and Operation.
2. With the Burner Output Knob set on HIGH, place the food on the Cooking Grid for 1-2 minutes, or until food lifts without sticking.
3. Turn the food and repeat Step 2.
4. Depending upon your taste, continue cooking on HIGH, turning the food frequently, or adjust the Burner Output Knob between LOW and "medium" and continue cooking until the food is cooked to your satisfaction. Turn as necessary (generally every one to three minutes).

During the searing period, flashing might occur when juices vaporize on contact with the Radiant Glass Emitter. The flashes and smoke greatly enhance the flavor by "char-broiling" the food.

Smoking Method

The G-Series grill can be used very effectively as a smoker. Use dry wood pellets or wet woodchips (small chips, not chunks), placing them directly on the Radiant Glass Emitter below or adjacent to the intended location of the food. Follow the procedures below:

1. Soak woodchips in hot water for at least 30 minutes prior to use.
2. Follow the Burner Ignition Procedures for slow cooking in Step 6 on page 9. Then, turn the Burner Output Knobs to LOW or Medium-LOW.
3. Add woodchips by lifting the cooking grid with a spatula or by dropping them through the grids onto the glass.
4. For best results, close the hood.
5. When you are finished cooking, be sure to turn all burners to OFF. Allow the grill to cool.
6. Remove ashes and wipe Radiant Glass Emitter with a damp paper towel before next use of grill.

Helpful Hints in Cooking

1. Use the proper tools. Use long handled tongs, spatula, knife, and mitts or a hot pad for handling hot items. When turning or moving foods, use tongs or a spatula, instead of a fork. Piercing the food with a fork lets the natural juices and flavor escape.
2. Start slowly. Infra-red grilling is unlike other outdoor cooking methods. It may take you time to get used to the fast cooking process. As a benchmark, foods which generally cook in 20 minutes or less on conventional grills cook in about one-half to two-thirds the conventional time on a TEC Infra-red grill. Please refer to the section entitled SAMPLE COOKING METHODS on page 13.

Flame Flare-up Control

To minimize flame flare-ups:

- Trim excess fat from food.
- Preheat the grill in accordance with the Burner Ignition Procedures on page 9 before each use.
- Reduce heat and reposition food while cooking.
- When cooking hamburgers, do not use ground beef that is less than 80% lean.

Infra-red Cooking continued

Sample Cooking Methods

Unless otherwise noted, these cooking guidelines require *cooking with hood open*. Use this chart as a cooking guide. *Cooking times may vary, depending on thickness of food.*

FOOD	CONTROL SETTING	TOTAL COOKING TIME
Steak 1" Thick	High fire 2 min. each side	4 min. - Rare
	High fire 2 min. each side. Balance "medium" fire	6 min. - Medium
	High fire 2 min. each side. Balance "medium" fire	8 min. - Well Done
Hamburger 1/2" Thick	High fire 2 1/2 min. each side	5 min. - Medium
	High fire 3 min. each side	6 min. - Well Done
Chicken - Parts	High fire, 2 min. per side Balance medium low to low fire	20 to 25 min.
Chicken Breast 3/4" Thick, <i>Fileted</i>	High fire, 2 min. each side	8 to 10 min.
Hot Dogs	Medium-Low	4-6 min.
Pork Chops	Medium	6 min. per side
Spare Ribs	High fire 5 min.	20 min. per side
	Low to finish	Turn often
Lamb Chops	High fire 5 min.	15 min. per side
	Medium to finish	
Fish 1 lb.	Medium-Low	6-8 min. per side
Shrimp, <i>Shelled</i>	Medium-Low	3-4 min. per side
Kabobs	Medium-Low	4-5 min. per side (2 sides)
COOK WITH HOOD CLOSED		
Potatoes	Medium-Low	45-60 min. per side
Corn on the Cob	Medium-Low	20-30 min. per side
Onions	Medium-Low	20-30 min. per side
Lobster 1-1 1/2 lbs.	Medium-Low	15 min. per side
COOK ON ROTISSERIE WITH HOOD OPEN		
Chicken - Whole	High fire 10 min. Balance "medium" fire	1 hour, 20 min.
Rib-eye Roast	High fire 10 min. Balance "medium" fire	15 min./lb. - Rare
		20 min./lb. - Medium
		25 min./lb. - Well Done
Pork Roast	High fire 10 min. Balance "medium" fire	Always cook well done
		25 min./lb
Turkey 12-13 lbs.	Low fire, <i>Cook with hood closed</i>	3 hours, 30 min. until 175°F internal temp.

Maintenance and Cleaning

General Overview

Proper care, maintenance and cleaning will help ensure long life of your grill. Periodic cleaning will help avoid accumulations of flammable grease, fats, and other debris.

Because of the high intensity of the Infra-red burner, any drippings and food particles that fall onto the Radiant Glass Emitter or the burner surface are immediately incinerated. However, some debris and residue may remain. To remove this residue after cooking, turn the grill on HIGH for 5-10 minutes with the hood OPEN. The most important way to maintain the performance of the Infra-red burner is to do this after each use.

Maintenance

The RadiantWave requires very little maintenance. However, the burner venturi tube should be inspected for spider webs and other obstructions prior to each use. If any are found, clean the tube completely. A clogged tube can lead to a fire beneath the grill.

Care of Radiant Glass Emitter

Large amounts of charred residue allow the glass to retain heat beyond its specified tolerance, which may cause it to break. Removal of this residue prior to each use is therefore imperative. This is easy to accomplish with a large paint scraping razor when the glass is cool. Simply remove the cooking grids and scrape the charred residue off the glass. Then wipe off any remaining dust particles with a damp paper towel. No other cleaning of the glass is necessary to ensure its proper function. However, to improve its cosmetic appearance, additional cleaning may be done following the instructions under Cleaning at right.

Care should be taken to avoid harsh impact of the Radiant Glass Emitter with hard objects. This is particularly true of the beveled sides of the glass. Chips in the beveled sides greatly reduce the strength of the glass and render it more prone to breakage. Although scratches on the glass surface do not impair its function, avoid the use of cookware that may promote scratching, such as ceramic, glass ceramic, or pots and pans with ridges on

the bottom. In addition, pots and pans with copper or aluminum bases should be avoided because they may leave small, hard-to-remove deposits on the glass.

Protection of Burners

The burners of your grill are designed to provide a long life of satisfactory performance. However, there are steps you must take to prevent cracking of the burner's ceramic surfaces, which will cause the burners to malfunction. Following are the most common causes of cracks and the steps you must take to avoid them. **Damage caused by failure to follow these steps is not covered by your grill warranty.**

IMPACT WITH HARD OBJECTS - Never allow hard objects to strike the ceramic. If objects such as these fall onto the ceramic, it is likely to crack the ceramic. You should take particular care when inserting or removing the Radiant Glass Emitter.

IMPAIRED VENTILATION OF HOT AIR FROM GRILL - In order for the burners to function properly, hot air created by the burners must have a way to escape the grill. If the hot air is not allowed to escape, the burners may become deprived of oxygen, causing them to backfire, especially if the burner output is set at HIGH. If this occurs repeatedly, the burners may crack. This is the reason your grill was designed with ventilation louvers and other openings, and the accessories were designed to leave open space at the grill surface. These design features give the hot air an escape route. Accordingly, never operate your grill with very little or no open space at the cooking surface (the Radiant Glass Emitter and Cooking Grids provide sufficient open space).

Also, never cover the ventilation louvers or other openings with foil or other materials that prevent air flow. Specifically:

- Do not use accessories in combinations that cover the entire cooking surface with solid metal. Appendix A: Accessories contains further instructions as to proper use of accessories and warnings about improper use.
- Do not cover the entire surface with foil, a large pan, etc.
- For further burner maintenance instructions, see MAINTENANCE section.

Maintenance and Cleaning continued

Periodically inspect burner ignition electrode for residue build-up and proper height. The electrode should be 5/16" above the surface of burner.

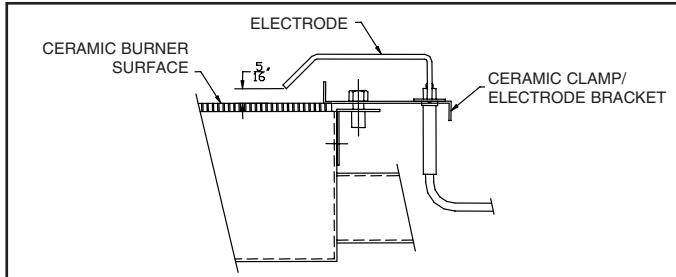

Figure 10. Burner Ignition Electrode Location

Cleaning

CAUTION: ALWAYS ALLOW THE GRILL TO COOL BEFORE CLEANING.

Radiant Glass Emitter

Cleaning required to maintain proper function of the Radiant Glass Emitter is discussed under Care of Radiant Glass Emitter at left. The cosmetic appearance of the glass may be improved through additional cleaning with ceramic cleaning creams. The following are the cleaning creams approved by the glass manufacturer:

- ELCO/Weimann CookTop Cleaning Creme
- Golden Ventures Cerama Bryte
- Hope's Cooktop Cleaning Cream
- Whirlpool Cooktop Cleaner

WARNING: DO NOT USE ABRASIVE SPONGES OR SCOURING PADS OF ANY TYPE. DO NOT USE CORROSIVE CLEANERS SUCH AS OVEN SPRAYS, STAIN REMOVERS, OR CLEANERS CONTAINING CHLORINE OR AMMONIA.

Prior to using an approved cream, scrape off any charred residue and wipe glass with a damp paper towel as described under Care of Radiant Glass Emitter. With a cool surface, apply a few dabs (the size of a dime) of an approved cleaner and work the cleaner over the glass with a damp paper towel as if you were cleaning a window. Clean the glass with clear water and wipe with a clean, dry paper towel.

Drip Tray

Remove debris and rinse with soap and water.

Heat Shield

If necessary, the Heat Shield may be removed for cleaning (See Figure 11.).

Cooking Grids

Leave the Cooking Grids in place for 5-10 minutes while the burners are on HIGH and the hood OPEN. The Cooking Grids may also be removed and cleaned with a brass or stainless steel bristle brush and soapy solution. Standard oven cleaners may be used for further cleaning. Wash the Cooking Grids thoroughly with dish detergent and warm water before using.

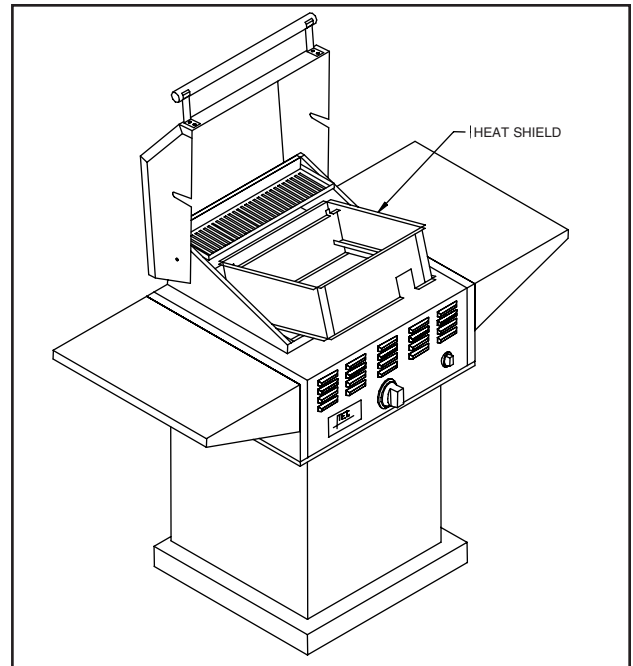

Figure 11. Heat Shield Removal

Replacement Parts

If you need Replacement Parts or Accessories, contact your TEC Authorized Dealer. See Appendix C of this manual for a listing of Replacement Parts and Accessories.

Appendix A: Accessories

Rotisserie

Cooking versatility is a trademark of the TEC grill. With the Rotisserie, you can add a new and exciting dimension to cooking.

Installing Rotisserie

Tools Required

- 3/8" wrench
- 7/16" wrench
- Flat-head screwdriver
- #2 Phillips-head screwdriver

1. Attach the Spit Rod bracket to the stationary hood wall with two (2) 1/4-20 x 1/2" screws, two (2) lock washers and two (2) nuts (supplied).
2. Attach the Rotisserie bracket to the stationary hood wall with two (2) 10-24 x 1/2" screws, and two (2) kee nuts (supplied). To ensure that the hood closes properly, the screw must be installed with the threads pointing downward into the grill through the rotisserie bracket and then the ledge on the outer side of the hood body (fixed portion of the hood).
3. Position the Rotisserie Motor on the Rotisserie Bracket and plug it into a grounded outlet.

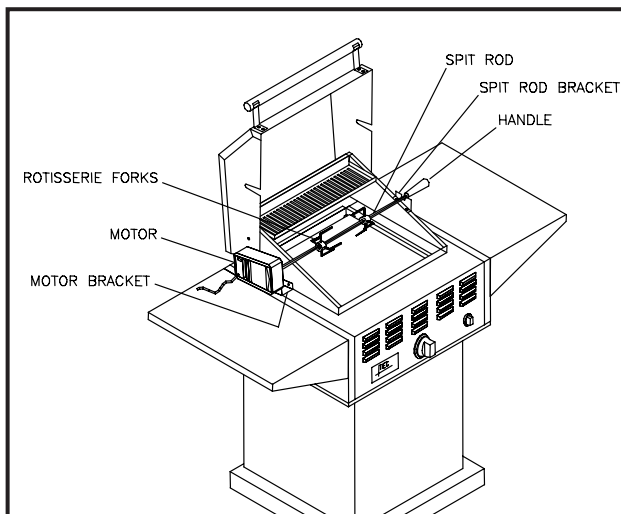

Figure 12. Rotisserie

The TEC Rotisserie has not been tested by CSA International.

Rotisserie Use

CAUTION: DO NOT USE THE ROTISSERIE IN THE RAIN.

1. The Cooking Grid may be removed or left in place.
2. Ignite the burner as described in the Burner Ignition Procedures on pages 9 and 10. After the burner ignites, operate the grill for 3 to 5 minutes on HIGH with the hood OPEN.
3. Turn the Burner Output Knob to LOW. Position the spit-rod in the center of the food, and tighten the forks into the ends of the food. Make sure the food is evenly balanced on the rod. Turn the Rotisserie ON. Adjust the Burner Output Knob to the desired cooking level.
4. You may cook with the hood open or closed. If you close the hood, monitor the food to ensure it is not over cooking. Generally, lower heat settings are required with the hood closed.
5. When you are finished cooking, be sure to turn the burners to OFF.

For best results, refer to the Infra-red Cooking section of this manual.

Appendix A: Accessories continued

Deep Fryer/Steamer

The Deep Fryer lets you cook foods that traditionally have been limited to indoor cooking. It's great for frying chicken, french fries, shrimp or fish; or for boiling corn or potatoes and cooking stews.

For your safety and the protection of your property keep a class A, B, C & D fire extinguisher on hand in case an oil fire occurs during use of this attachment.

WARNING: DO NOT LEAVE OIL / GREASE UNATTENDED.

WARNING: IN THE EVENT OF RAIN WHILE COOKING WITH OIL / GREASE, COVER THE COOKING VESSEL IMMEDIATELY AND TURN OFF THE APPLIANCE BURNER AND GAS SUPPLY. DO NOT ATTEMPT TO MOVE THE APPLIANCE OR COOKING VESSEL.

WARNING: WHEN COOKING WITH OIL / GREASE, DO NOT ALLOW THE OIL / GREASE TO EXCEED 350°F (177°C). DO NOT STORE OR USE EXTRA COOKING OIL IN THE VICINITY OF THIS OR ANY OTHER APPLIANCE.

Deep Fryer Use

CAUTION: DO NOT CLOSE THE HOOD WHILE USING THIS ATTACHMENT FOR FRYING. HOT COOKING OIL CAN CAUSE BURNS. ALWAYS WEAR OVEN MITTS WHEN USING THE DEEP FRYER AND USE EXTREME CAUTION WHEN HANDLING HOT COOKING OIL OR WATER.

OIL WILL BURN IF OVERHEATED. DO NOT LEAVE UNATTENDED WHILE HEATING. IF SMOKING OCCURS, REDUCE HEAT. IF OIL CATCHES FIRE, TURN OFF HEAT AND EXTINGUISH WITH A CLASS A, B, C & D FIRE EXTINGUISHER, OR COVER FRYER WITH STEAMER LID UNTIL COOLED. DO NOT PUT WATER ON HOT OR FLAMING OIL!

1. Remove the Cooking Grid.
2. After removing the Steamer attachment, place the Deep Fryer over the desired burner, on the Radiant Glass Emitter.
3. Fill the Deep Fryer one-third full with cooking oil or water (one-gallon). DO NOT OVERFILL.
4. Ignite the burner in accordance with the Burner Ignition Procedures at pages 9 and 10.
5. Operate the burner on HIGH for a total of

approximately 7 to 13 minutes **with the hood open** to properly heat cooking oil or water, then reduce heat. We suggest you use a candy thermometer (supplied) to check the temperature of the oil or water. However, do not rely on the thermometer readings in lieu of observing the cautions at lower left. You must remain alert for signs of over-heating and take steps to avoid an oil fire. Normally, 350°F to 375°F is sufficient for frying.

6. Turn the Burner Control Knob to between "medium" and LOW. Do not leave the burner on HIGH for an extended period.
7. Place the food into Deep Fryer with long-handled utensils, being careful not to allow the oil to splash out of the Deep Fryer.
8. After cooking, turn the burner to OFF. Let the grill and cooking oil or water cool to room temperature before attempting to remove the Deep Fryer/Steamer.

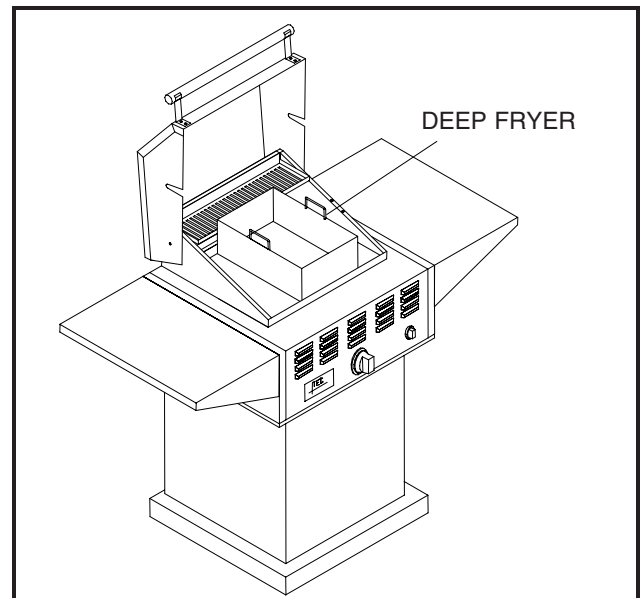

Figure 13. Deep Fryer

The TEC Deep Fryer has not been tested by CSA International.

Appendix A: Accessories continued

Steamer

The Steamer is great for steaming vegetables like broccoli, potatoes, carrots or cauliflower. It's also ideal for seafood such as shrimp, clams and oysters. The Steamer is used with the Deep Fryer.

CAUTION: STEAM CAN CAUSE SERIOUS BURNS. ALWAYS WEAR OVEN MITTS. USE EXTREME CAUTION WHEN REMOVING STEAMER LID.

Steamer Use

1. Remove the Cooking Grid.
2. Place the Deep Fryer/Steamer over the burner on the glass emitter.
3. Fill the bottom of Fryer with $\frac{1}{2}$ " to $\frac{3}{4}$ " of water or other non-flammable liquid (wine, etc.). **Repeat this throughout the cooking process so that the liquid level is maintained.**
4. Place the Steamer Screen in the bottom of the Deep Fryer. Cover the Deep Fryer with the Steamer lid.
5. Ignite the burner as described in the Burner Ignition Procedures on pages 9 and 10. After the burner ignites, operate the grill for 5 minutes with the hood open.
6. Continue to operate the burner on HIGH until the water or other liquid boils.
7. Turn the burner control dial to "medium" or LOW. Do not leave the burner on HIGH for an extended period.
8. Remove the Steamer lid and add the food.
9. Cook until desired texture is attained.
10. After cooking, turn the Burner Output Knob to OFF. Let the grill and liquid cool to room temperature before removing Deep Fryer/Steamer.

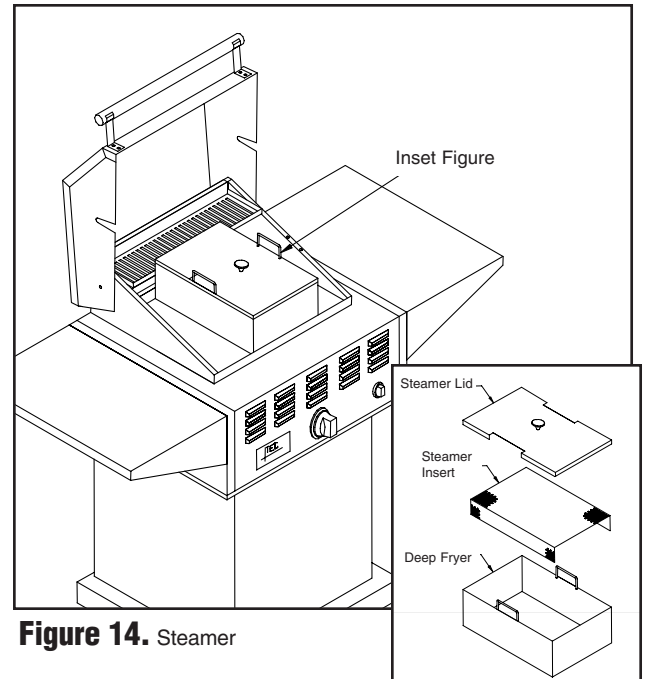

Figure 14. Steamer

The TEC Deep Fryer has not been tested by CSA International

Appendix A: Accessories continued

Griddle

This Griddle provides a surface for you to use your grill for pan frying foods such as fajitas, bacon, eggs, sausage, french toast and pancakes, and for blackening fish and meats. **After each use, the Griddle should be thoroughly washed with warm soap and water.**

Griddle Use

1. Remove the Cooking Grid.
2. Place the Griddle over the burner.
3. Follow the Burner Ignition Procedures at pages 9 and 10 and after the burner ignites, operate the grill for on high 5 minutes.
4. Adjust Burner Output Knob to “medium” or LOW for frying or to “medium” or HIGH for blackening.
5. Turn the Burner Output Knob to OFF when you are finished cooking. Let the grill and Griddle cool to room temperature before removing the Griddle.

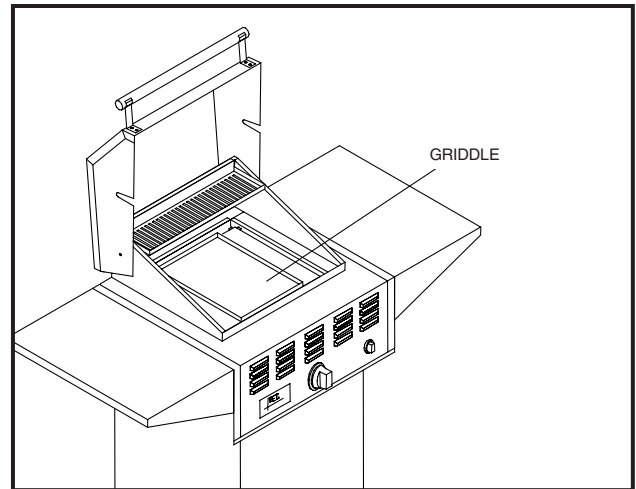

Figure 15. Griddle

The TEC Griddle has not been tested by CSA International.

Appendix A: Accessories continued

Wok

Enjoy stir-fry cooking on your TEC grill with the Wok accessory. Using high temperature, you can quickly cook chicken, beef, shrimp or assorted vegetables. **After each use, the Wok should be thoroughly washed with soap and warm water and dried and rubbed with cooking oil to prevent rusting.**

Wok Use

1. Remove the Cooking Grid.
2. Place the Wok support over the burner.
3. Place the Wok in the Wok support.
4. Ignite the burner as described in the Burner Ignition Procedures on pages 9 and 10. After the burner ignites, operate the grill for 5 minutes on HIGH with the hood open.
5. Adjust Burner Output Knob to desired heat setting.
6. After cooking, turn the Burner Output Knob to OFF. Let the grill and Wok cool before attempting to remove Wok.

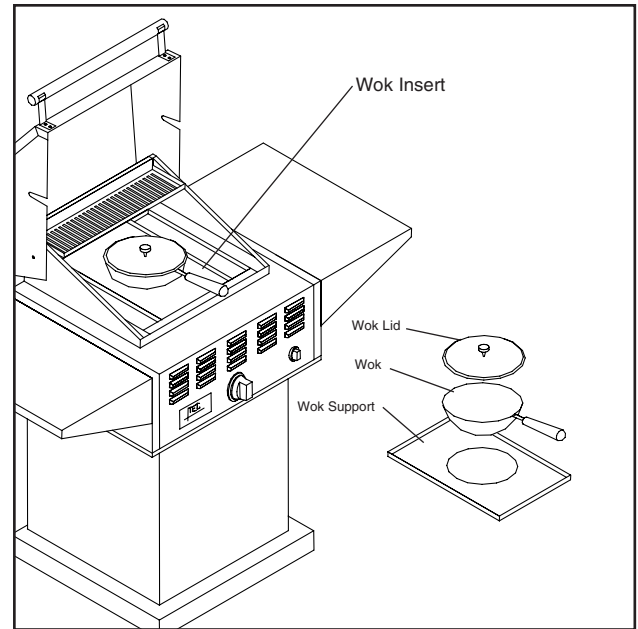

Figure 16. Wok

The TEC wok has not been tested by CSA International.

Appendix B: Replacement Parts

ORDER NO.	DESCRIPTION
RFM2105.....	Burner Assembly
STBP	Burner Head
RHW0411	Radiant Glass Emitter
RHW0283	Gas Valve, Burner
STBK	Knob, Burner Output
RFM2106.....	Cooking Grid
RFM2132.....	Drip Tray
RFM2119.....	Warming Rack
RFM2104.....	Heat Shield
HW0266	Regulator, w/ hose, LP gas
REGLP	Regulator, LP gas (build-in applications)
REGNT	Regulator, Natural gas (build-in applications)
ORI40	Orifice, Natural gas, #40
ORI53	Orifice, LP gas, #53
ST30IGN.....	Igniter, Rotatory
REGNT	Regulator, Natural gas (build-in applications)
RHW1626	Wire, Ignition, 10" Lg.
RHW0277	Ignition Rod (Electrode)

Appendix C: Troubleshooting

PROBLEM	PROBABLE CAUSE	REMEDY
Burner will not light.	<ul style="list-style-type: none"> a. Lack of gas supply. b. Obstruction in burner orifice. 	<ul style="list-style-type: none"> a. Ensure gas supply valve is in open position or fill LP gas cylinder, if applicable. b. Clean burner orifice (See Fig. 8, Pg. 10).
Burner will light with a match, but the igniter will not spark.	<ul style="list-style-type: none"> a. Igniter wire has come unplugged from backside of igniter. b. Dirty ignition electrode. c. Incorrect spark gap. d. Defective igniter. 	<ul style="list-style-type: none"> a. Remove cooking grid, glass and heat shield and tug on igniter wire to determine if it is secure. If necessary, plug in igniter wire and make sure it is firmly secured. b. Clean burner electrode (See Fig. 10, Pg 14). If necessary rub probes with fine sandpaper to remove residue. c. Adjust spark gap to 1/8". d. Replace igniter.
Burner output at HIGH setting is too low. (Cooks more slowly than previously experienced or makes a rumbling noise and has a fluttering blue flame at burner surface.)	<ul style="list-style-type: none"> a. Lack of gas supply. b. Kinked regulator hose. c. Insufficient gas pressure despite ample gas supply. This may result when Burner Output Knob is very quickly turned from OFF to HIGH with the gas supply valve open, or if the gas supply valve is opened AFTER the Burner Output Knob is turned from OFF to HIGH. Both actions may cause the regulator to shut off gas supply as if there is a leak in the line. d. Dirty or clogged orifice. e. Venturi tube obstructed by spider or spider webs, wasp nest, or other foreign matter. f. Regulator is defective or needs adjustment. g. Cracked burner. 	<ul style="list-style-type: none"> a. Ensure gas supply valve is in open position or fill LP gas cylinder, if applicable. b. Reposition regulator hose, as necessary. c. Return Burner Output Knob to OFF. Make sure gas supply valve (at LP cylinder or nat. gas line) is open. Then, when turning the gas on as instructed on pg. 9-10, turn Burner Output Knob SLOWLY from OFF to HIGH. d. Clean burner orifice (See Fig. 8, Pg. 10). e. Clean out all obstructions from venturi tube. (See Fig. 8, Pg. 10). f. Adjust or replace regulator, as necessary. g. Contact TEC Authorized Dealer. Replace ceramic burner head.
Burner output at LOW setting is too hot (or too cool).	<ul style="list-style-type: none"> a. Low heat setting is adjusted too high (or too low). 	<ul style="list-style-type: none"> a. Reduce (or increase) low heat setting following procedures on Page 11.
Burner backfires (during operation burner abruptly makes a loud "woosh" sound, followed by a continuous blow-torch type sound and grows dim).	<ul style="list-style-type: none"> a. Burner overheated due to inadequate ventilation (too much cooking surface covered). b. Cracked ceramic. c. None of the above. Probable cause is leak in packing within or under ceramic burner head. 	<p><i>In all cases turn Burner Output Knob to OFF position and let it cool for at least two minutes; then:</i></p> <ul style="list-style-type: none"> a. Remove any object covering the entire cooking surface or any object obstructing the ventilation openings. Allow the burner to cool for approximately two minutes, then re-light the burner. b. Allow burner to cool and inspect very closely for cracks (which may be nearly invisible). If cracks are found, contact TEC Authorized Dealer to replace burner head. c. Contact TEC Authorized Dealer. Replace fiber insulation packing under burner head.

Notes

Notes
